



POWERHOUSE DIESEL GENERATORS

RUGGED. RELIABLE. POWERFUL.

**RUGGED SERIES
INDUSTRIAL GRADE
DIESEL GENSETS**



**Kubota D1105-BGGE Engine
EPA TIER 4 Compliant
8.5 kWe**

**POWERHOUSE DIESEL GENERATORS
RUGGED. RELIABLE. POWERFUL.**

1616 James P Rodgers Dr. Valdosta, GA. 31601
(229)671-9171 Fax:(229)244-5326
www.PDGPOWER.com



For North American Market

INDUSTRIAL DIESEL ENGINE

KUBOTA 05 SERIES (3-cylinder)

D1105-E3B



RATED POWER

18.5kW@3000rpm



Photograph may show non-standard equipment.

PERFORMANCE CURVE

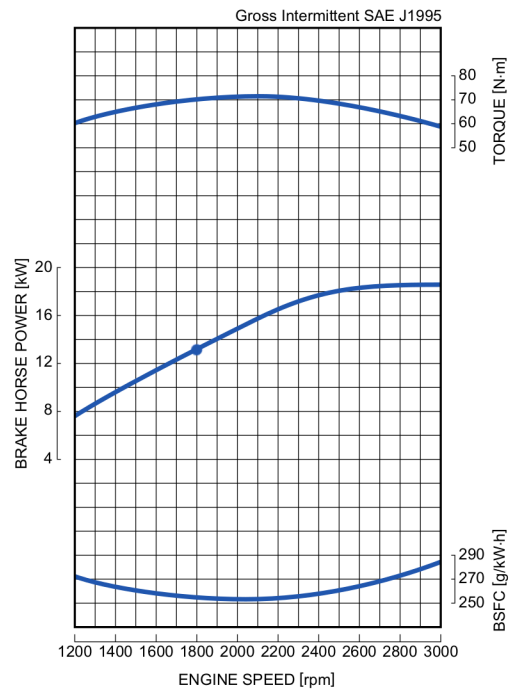

FEATURES and BENEFITS

Emissions

- The D1105 naturally aspirated engine (3000rpm) complies with EPA Tier 4 emissions regulations. These are the most stringent emissions regulations in the world in this class.

Durable Power

- The Kubota 05 Series is an established leader in its horsepower range and has been the preferred power source of various industrial equipment manufacturers.
- The D1105 NA engine offers a seamless transition from Tier 2 to Tier 4 by maintaining the same footprint and hardware mounting points with only slight performance changes from the Tier 2 engine.

Clean and Quiet Power

- Kubota's original E-TVCS (Three Vortex Combustion System) has been improved. The combustion chamber and piston recess were optimized to achieve a 50% lower particulate matter (PM) level.

GENERAL SPECIFICATION

Model		D1105-E3B
Emission Regulation		Tier 4
Type		Vertical 4-cycle Liquid Cooled Diesel
Number of Cylinders		3
Bore	mm (in)	78.0 (3.07)
Stroke	mm (in)	78.4 (3.09)
Displacement	L (cu.in)	1.123 (68.53)
Combustion System		IDI
Intake System		Naturally Aspirated
Maximum Speed	rpm	3000
Output: Gross Intermittent	kW	18.5
	hp	24.8
	ps	25.2
Direction of Rotation		Counterclockwise Viewed on Flywheel
Oil Pan Capacity	L (gal)	5.1 (1.35)
Starter Capacity	V-kW	12-1.2 [US] / 12-1.4 [EU]
Alternator Capacity	V-A	12-40
Length	mm (in)	497.8 (19.60)
Width	mm (in)	396.0 (15.59)
Height (1)	mm (in)	602.0 (23.7)
Height (2)	mm (in)	227.6 (8.96)
Dry Weight	kg (lb)	93.0 (205.0)

*Specification is subject to change without notice.

*Output: Gross Intermittent SAE J1995

*Dry weight is according to Kubota's standard specification.

When specification varies, the weight will vary accordingly.

DIMENSIONS

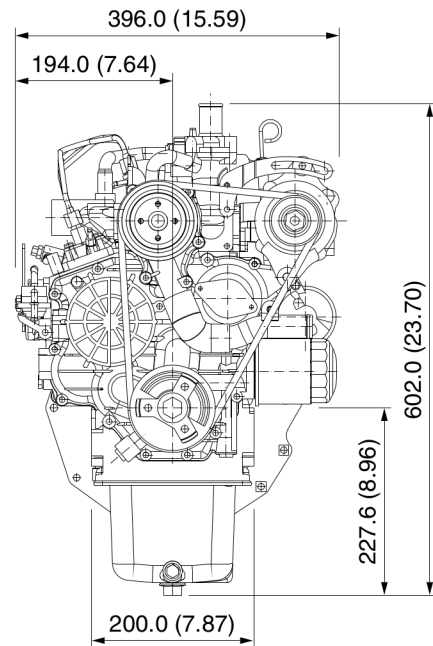
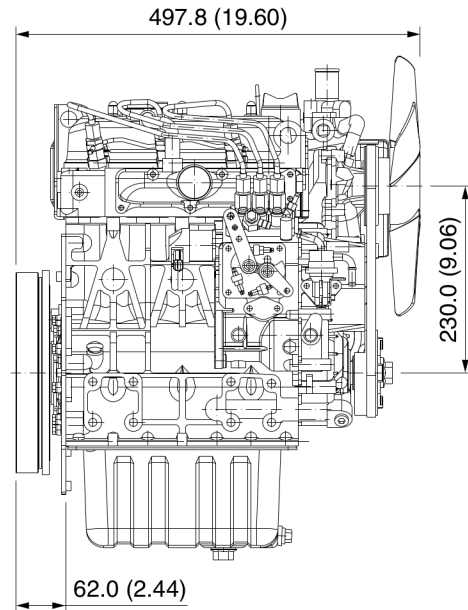

Your Driving Force
KUBOTA ENGINE

KUBOTA Corporation

2-47, Shikitsuhigashi 1-chome, Naniwa-ku, Osaka, 556-8601 Japan
Fax: 06-6648-3521

<http://www.engine.kubota.ne.jp>

STAMFORD

S0L2-G1 Winding 06 / 706

S0L2-G1 - Technical Data Sheet

Standards

Stamford industrial alternators meet the requirements of IEC EN 60034 and the relevant section of other international standards such as BS5000, VDE 0530, NEMA MG1-32, IEC34, CSA C22.2-100 and AS1359. Other standards and certifications can be considered on request.

Quality Assurance

Alternators are manufactured using production procedures having a quality assurance level to BS EN ISO 9001.



Excitation and Voltage Regulators

Excitation System	
AVR Type	AVR Power
AS540	Self-Excited / Aux winding
Voltage Regulation	± 1%
No Load Excitation Voltage (V)	12 V
Full Load Excitation Voltage (V)	48 V

STAMFORD®

S0L2-G1 Winding 06 / 706

Electrical Data		
Insulation System	Class H	
Stator Winding	Double Layer Concentric	
Winding Pitch	Two Thirds	
Winding Leads	4	
Winding Number	06 / 706	
Number of Poles	4	
IP Rating	IP23	
RFI Suppression	EN 61000-6-2 & EN 61000-6-4, refer to factory for others	
Waveform Distortion	NO LOAD < 2.5% NON-DISTORTING BALANCED LINEAR LOAD < 5.0%	
Short Circuit Ratio	1/Xd	
Steady State X/R Ratio	5.2	
60 Hz		
Telephone Interference	TIF<75	
Voltage Series/ Voltage Parallel	240/120	240/120
Power Factor	0.8	1.0
kVA Base Rating (Class H)	14.5	15.6
Saturated Values in Per Unit at Base Ratings and Voltages		
Xd Dir. Axis Synchronous	0.940	1.011
X'd Dir. Axis Transient	0.109	0.117
X''d Dir. Axis Subtransient	0.108	0.116
Xq Quad. Axis Reactance	0.834	0.897
X''q Quad. Axis Subtransient	0.139	0.150
XL Stator Leakage Reactance	0.075	0.081
X2 Negative Sequence Reactance	0.212	0.228
X0 Zero Sequence Reactance	0.071	0.076
Unsaturated Values in Per Unit at Base Ratings and Voltages		
Xd Dir. Axis Synchronous	1.250	1.345
X'd Dir. Axis Transient	0.125	0.135
X''d Dir. Axis Subtransient	0.126	0.136
Xq Quad. Axis Reactance	0.859	0.924
X''q Quad. Axis Subtransient	0.167	0.179
XL Stator Leakage Reactance	0.085	0.091
X2 Negative Sequence Reactance	0.254	0.274
X0 Zero Sequence Reactance	0.083	0.089
Time Constants (Seconds)		
T'd TRANSIENT TIME CONST.	0.025	
T''d SUB-TRANSTIME CONST.	0.001	
T'do O.C. FIELD TIME CONST.	0.508	
Ta ARMATURE TIME CONST.	0.012	

STAMFORD®

S0L2-G1 Winding 06 / 706

Resistances in Ohms (Ω) at 22°C	
Stator Winding Resistance (Ra)	0.141 Ω per phase series connected
Rotor Winding Resistance (Rf)	0.644 Ω
Exciter Stator Winding Resistance	14.624 Ω
Exciter Rotor Winding Resistance	0.135 Ω per phase
Positive Sequence Resistance (R1)	0.176 Ω
Negative Sequence Resistance (R2)	0.203 Ω
Zero Sequence Resistance (R0)	0.176 Ω
Aux Winding Resistance (with winding 706 only)	2.731 Ω
Mechanical data	
Cooling Air	0.126 m ³ /sec (50Hz)
Shaft and Keys	All alternator rotors are dynamically balanced to better than BS6861: Part 1 Grade 2.5 for minimum vibration in operation.
Bearing	Single Bearing
Weight Complete Alternator	104.6kg
Weight Wound Stator	40.5kg
Weight Wound Rotor	36.8 kg
Moment of Inertia	0.127kgm ²
Shipping weight in a Crate	143 kg
Packing Crate Size	930X590X760 mm
Maximum Over Speed	2250 RPM for two minutes
Bearing Drive End	N/A
Bearing Non-Drive End	Ball Bearing, 6305-2RS1

S0L2-G1 Winding 06 / 706 RATINGS AT 0.8/1.0 POWER FACTOR

Class - Temp Rise		Standby - 163/27°C		Standby - 150/40°C		Cont. H - 125/40°C		Cont. F - 105/40°C	
60 Hz	Series (V)	240	240	240	240	240	240	240	240
	Parallel(V)	120	120	120	120	120	120	120	120
	Power Factor	0.8	1.0	0.8	1.0	0.8	1.0	0.8	1.0
	kVA	15.8	17.1	15.4	16.6	14.5	15.6	13.1	14.1
	kW	12.6	17.1	12.3	16.6	11.6	15.6	10.5	14.1
	Efficiency (%)	77.9	81.6	78.2	82.0	79.1	82.8	80.2	83.7
	kW Input	16.2	21.0	15.8	20.2	14.7	18.8	13.1	16.8

De-Rates

All values tabulated above are subject to the following reductions:

- 3% for every 500 meters by which the operating altitude exceeds 1000 meters above mean sea level
- 3% for every 5°C by which the operational ambient temperature exceeds 40°C
- For any other operating conditions impacting the cooling circuit please refer to applications

Note: Requirement for operating in an ambient exceeding 60°C and altitude exceeding 4000 meters must be referred to applications.

Note: Continuous development of our products means that the information contained in our data sheets can change without notice, and specifications should always be confirmed with Cummins Generator Technologies prior to purchase.



Optional Enclosure and Fuel Tank Pictured

Kubota Powered 8,500 Watt Diesel Generator - Whether for a work site, cabin, lodge, or standby emergency power, this Kubota diesel will do the job every day. Day after day. This unit operates at 1800 RPM and with its super quiet muffler, acoustic dampening air intake system and 4 point vibration mounts, runs smooth and quiet.

Generator is fully customizable. From enclosure to fuel tank to controls to trailer, you choose the option that is right for you. And, as an added benefit, you will always have the flexibility to upgrade options later.

This unit features a Kubota D1105-BG 1800 RPM diesel engine, brushless generator, liquid cooling, muffler, +/- 1% AC voltage regulation to protect your electronics, oil & water safety shutdowns, high volume air filter, steel skid base, glow plugs for cold weather starting and control panel w/ turn-key start and hour meter.

Options	Price
55 Gallon Fuel Drum Kit	+ \$225
Sound Proof Enclosure	+ \$3699
50 Gallon Subbase Fuel Tank	+ \$1895
100 Gallon Subbase Fuel Tank	+ \$2589
100 Amp Automatic Transfer Switch	+ \$1599

Contact if you need double wall and/or UL Fuel Tank
Contact if your tank needs to be D.O.T.

ENGINE

Model	Kubota D1105-E3BG
Type	Vertical 4-Cycle
Fuel Injection System	Indirect Injection
Oil Capacity (w/ Oil Filter)	Approx. 4.5 qts
Horsepower	17.6 HP @ 1800 RPM
RPM	1800
Displacement	1.1 L
Cylinders	3
Bore & Stroke	3.07 in. x 3.46 in.
Cylinder Block	Cast Iron w/ Cast Iron Sleeves
Cooling	Liquid-Cooling, Pushor Fan
Coolant Capacity	Approx. 6 Qts
Fuel	No. 2 Diesel
Cold Weather Starting Aid	Glow Plugs
Starting System	Electric

Fuel Consumption

Consumption at 1/2 load	0.41 gallons/hour
Consumption at 3/4 load	0.63 gallons/hour
Consumption at full load	0.84 gallons/hour

Power One-Phase	
Load Amperage at 120 volts	
Maximum Load	70 Amps
Continous Load	80 Amps
Load Amperage at 240 volts	
Maximum Load	35 Amps
Continous Load	35 Amps
Sound Level @ 23 ft(7 m) at full load	70 dB(A)

Output 8,500 watts

Controls

Turn-Key Start	Standard
Hour Meter	Standard
Water Temperature Shutdown	Standard
Oil Pressure Shutdown	Standard

Contact if 2 wire auto start is needed

Installation Data

Fuel Inlet Hose Size	3/8"
Fuel Return Hose Size	5/16"
Minimum Power Lead Size	No. 4 AWG
No. Power Lead Conductors	4
Exhaust Outlet	2" OD Muffler Outlet
Coolant Recommendation	Mixture: 1/2 Anti-Freeze & 1/2 Water
Fuel Inlet & Return Location (Facing Radiator)	Left-Side
Exhaust Direction (Facing Radiator)	Right-Side
Power Output Location (Facing Radiator)	Back-Side
Service Points (Facing Radiator)	Oil Fill: Left-Side Oil Drain:Left-Side Air Filter: Back-Side Oil Filter: Left-Side Fuel Filter: Left-Side
Battery Type	12 VDC - 1000 CCA
Engine Oil Type	SAE 15W-40

Dimensions

Length	48"
Width	19-1/2"
Height	32"
Dry weight	550 lbs

Recommended Maintenance Schedule

Replace Oil Filter	500 hours / 12 months
Replace Fuel Filter	500 hours / 12 months
Replace Air Filter	500 Hours / 12 months
Replace Engine Coolant	2000 Hours / 24 months
Exercise Generator Under Load	Once each month
Change Oil	500 hours / 12 months

Fuel Tank Options Available



Custom D.O.T. and UL Tanks For all Applications

Enclosures Available



PDG Enclosures are made with Aluminum and are coated with industrial grade synthetic powder coat for maximum durability. Fasteners, hinges, latches are stainless steel..



Standard Enclosure Color is PDG Tan. Additional Colors are Available Upon Request

POWERHOUSE DIESEL GENERATORS
RUGGED. RELIABLE. POWERFUL.

Lug and Camlock Connections Available



Various Optional D.O.T. Trailer Configurations Available



Various Optional D.O.T. Trailer Configurations Available

POWERHOUSE DIESEL GENERATORS
RUGGED. RELIABLE. POWERFUL.

1616 James P Rodgers Dr. Valdosta, GA. 31601
(229)671-9171 Fax:(229)244-5326
WWW.PDGPOWER.COM